

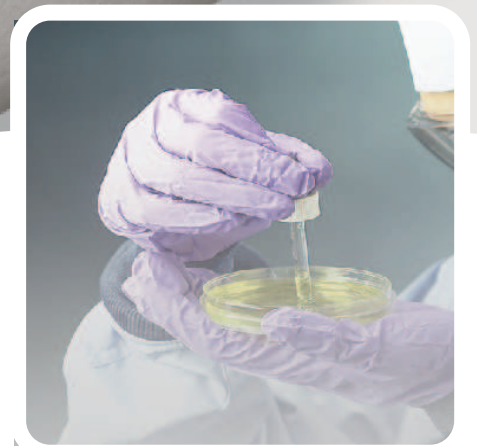

Saunders MKIII Body Forging



CHEMPHARMA  
FLOW SOLUTIONS

[www.cranecchempharma.com](http://www.cranecchempharma.com)

# Saunders MKIII Body Forging

The Saunders MKIII forged body supersedes the MKII forged body for 2-way applications requiring ASME BPE compliance and optimum performance. Weld end length has been increased to 40mm (1.50") minimum to facilitate orbital welding and to comply with ASME BPE Standard.

It features a reduced body mass and profile -- up to 30% in some sizes. Reduced body mass means less time and energy are required to bring the body to temperature during heat sanitization and reduced cool down time.



### Additional Features Include:

- Designed to comply with ASME BPE Requirements
- Dedicated to 16 gauge tube OD applications
- 316L SS ASTM A-182
- Controlled Sulfur Weld Chemistry per ASME BPE Table DT-3
- Improved flow rates and lower pressure drops
- Lower mass body for reduced energy requirements for heat sanitization - plus reduced cycle times - faster heat up and cool down
- Lighter body for easier installation of both autoweld and clamp end bodies
- Reduced centerline to bonnet flange means shorter installed height
- Defined bottom pad for marking to BPE Standard:
  - Standard Sizes: 0.50" (DN15) - 3.00" (DN80)
  - Bio-Seal Sizes: 0.25" (DN08) - 0.50" (DN15)
- Forging is manufactured from custom lots of stainless steel produced to Saunders specification and in compliance with:
  - 316L ASTM A-182
  - EN 10222-5, DIN 1.4435
  - ASME BPE for Controlled Sulfur, 0.005-0.017%

## MKIII Drain Angles

Size	Drain Angle
0.50" (DN15)	43°
0.75" (DN20)	35°
1.00" (DN25)	31°
1.50" (DN40)	30°
2.00" (DN50)	27°
2.50" (DN65)	20°
3.00" (DN80)	22°

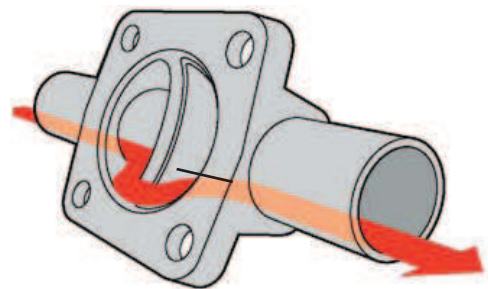

System drainability is a function of many variables including system design and is the responsibility of the system designer and installer.

# Saunders MKIII Body Forging

Saunders MKIII forgings feature a full 1.50" turn back on sizes 0.50" to 2.50" and 1.75" turn back on 3.00" size to facilitate orbital welding.

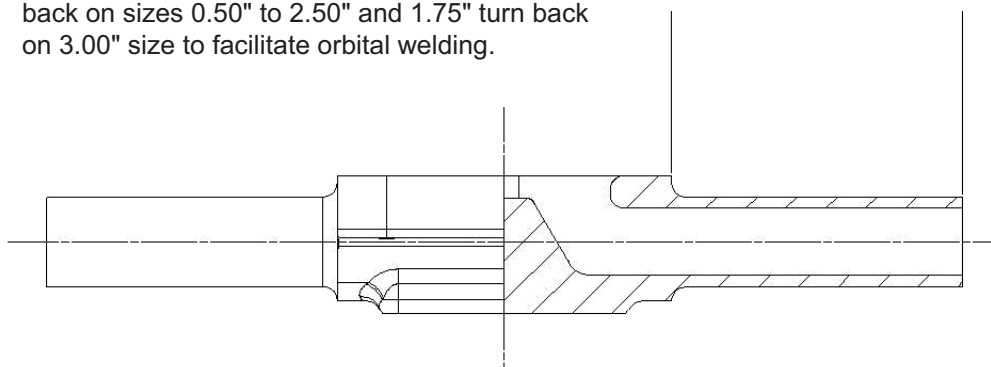

Saunders MKIII Body Forging Turn Back							
Size	0.50" (DN15)	0.75" (DN20)	1.00" (DN25)	1.50" (DN40)	2.00" (DN50)	2.50" (DN50)	3.00" (DN50)
Turn Back	1.50" (40mm)	1.50" (40mm)	1.50" (40mm)	1.50" (40mm)	1.50" (40mm)	1.50" (40mm)	1.75" (46mm)

PDF, AUTOCAD™ AND 3D MODEL FILES OF SAUNDERS HC4 ASEPTIC DIAPHRAGM VALVES WITH FULL DIMENSIONS ARE AVAILABLE VIA SAUNDERS WEB BASED DRAWING LIBRARY AT: [HTTP://DRAWINGS.CRANEFLOW.COM](http://DRAWINGS.CRANEFLOW.COM).

## MKIII Smaller Mass & Lighter Weight

### Benefits:

- 30% Smaller Forging
- Lighter Finished Body = Easier Installation
- Smaller Mass = Less Energy Required to Reach Sterilization Temperature, Faster Heat Up and Cool Down

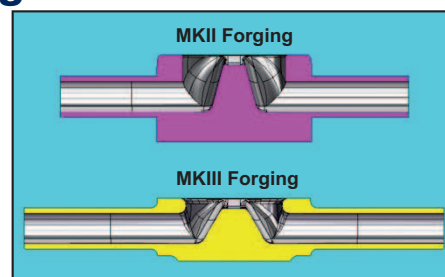

## MKIII Improved Flow Characteristics

	Bio-Seal	0.50" (DN15)	0.75" (DN20)	1.00" (DN25)	1.50" (DN40)	2.00" (DN50)	2.50" (DN50)	3.00" (DN50)
20%	1.06	1.20	1.25	6.40	14.60	23.40	42.10	65.30
50%	1.30	2.20	3.40	10.50	26.70	45.90	74.70	106.70
70%	1.11	2.50	4.60	12.00	31.00	51.40	82.80	123.30
100%	1.87	2.50	5.50	13.10	35.20	60.40	95.80	156.50

Values in US gallons.



CHEMPHARMA  
FLOW SOLUTIONS

## MKIII Forging - Size Range

- Bio-Seal through 3.00"
- One forging for autoweld and clamp ends
- Integral auto weld ends
- Integral clamp ends
  - Short pattern clamp ends to ASME BPE
  - Long pattern clamp ends to EN558 Series 7



## MKIII Body Forging Features Overview

- Uses same diaphragms and top works as previous MKII Forging
- Available in all ASME BPE surface finishes
- Has hash marks to indicate self drain angle
- Bodies are heat code stamped (on underside of bonnet flange) and are supplied with MTRs
- Landing pad on bottom of forging
- Marked as per ASME BPE

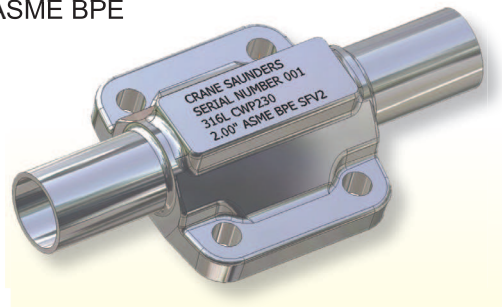

**Represented By:**

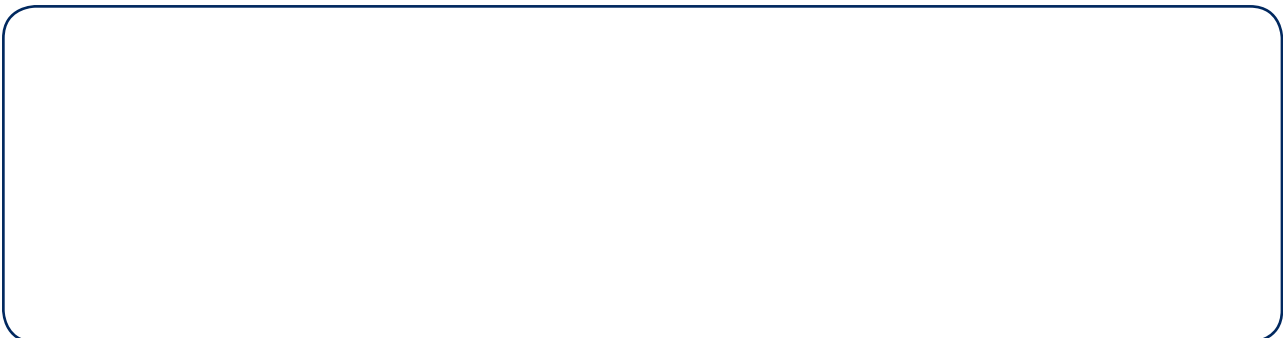

Crane ChemPharma Flow Solutions  
Saunders Bio-Pharm  
9860 Johnson Road  
Montgomery, Texas 77316

Phone: 926-588-4447  
Fax: 936-588-8304  
[www.cranesaunders.com](http://www.cranesaunders.com)  
[www.drawings.craneflow.com](http://www.drawings.craneflow.com)